



MANUAL DE MONTAGEM
ASSEMBLY INSTRUCTIONS
INSTRUCCIONES DE MONTAJE

COD BR: BAM 09

Sumário Summary Resumen

Introdução Introduction Introducción	3
Antes de começar Before starting Antes de comenzar	4
Evite acidentes Avoid accidents Evitar accidentes	4
Dimensões e ferramentas Dimensions and tools Dimensiones y herramientas	5
Identificação das peças Identifying parts Identificación de las piezas	6
Acessórios incluídos na caixa Hardware included in box Accesorios incluidos en la caja	7
Montagem do móvel Furniture assembly Montaje del mueble	8

Introdução Introduction Introducción

Leia atentamente este manual e siga os passos indicados para que o produto não perca a garantia e também para uma perfeita montagem.

For the perfect fit, please read this manual carefully and follow indicated steps.

Lea este manual y siga los pasos para que el producto no pierda la garantía y también para el ajuste perfecto.

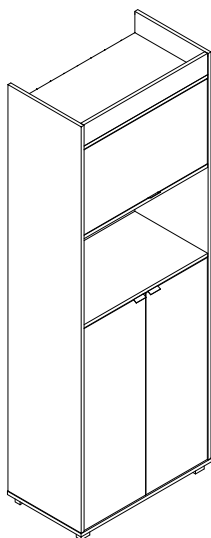

Antes de começar Before starting Antes de comenzar

Antes de começar a montagem prepare o ambiente, deixando-o completamente limpo e com bom espaço para iniciar o trabalho.

Prepare the room before starting the assembly, leaving it completely clean and the area in good condition to start the work.

Antes de comenzar el montaje preparar el ambiente, dejándolo completamente limpio y con bueno espacio para comenzar el trabajo.

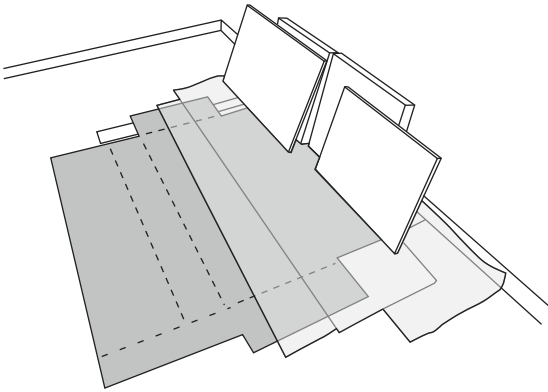

Utilize o papelão da própria embalagem para separar e apoiar as peças retiradas das caixas.

Use the cardboard of the packaging to separate and support the parts removed from the boxes.

Utilice el cartón de la embalaje para separar y apoyar las piezas desmontadas de las cajas.

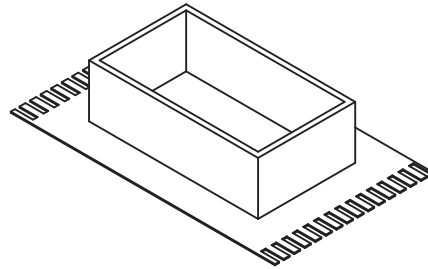

Forre a área de montagem com um cobertor ou tapete. Assim, você evita avarias nas peças durante o processo de montagem.

Cover the assembly area with a blanket or carpet to avoid damaging the parts during the assembly process.

Cubrir la zona de ensamble con una manta o alfombra. De este modo, se evitan daños en las piezas durante el proceso de montaje.



Evite acidentes Avoid accidents Prevenir accidentes

Solicitamos observar atentamente as orientações de montagem como: fixação do produto na parede, colocação de cola em locais específicos necessários, o peso suportado pelo produto, etc...

You are requested to carefully observe the assembly instructions regarding: fixing of products to the wall, adding glue where indicated, product weight limit, etc.

Pedimos que lea atentamente las instrucciones, principalmente las informaciones de fijación del producto en la pared, colocación de pegamento en local específico y necesario, el peso soportado por el producto etc...

Não escale ou se apoie no móvel.

Do not climb or lean on the furniture.

No se suba ni se apoye en el mueble.

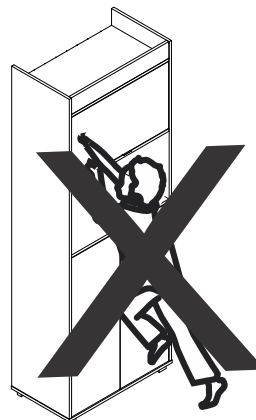

Dimensões e ferramentas
Dimensions and tools
Dimensiones y herramientas

Dimensões:

L: 675 A: 1850 P: 380 mm

Dimensions:

W: 26.57 H: 72.83 D: 14.96 inches

Dimensiones:

L: 675 A: 1850 P: 380 mm

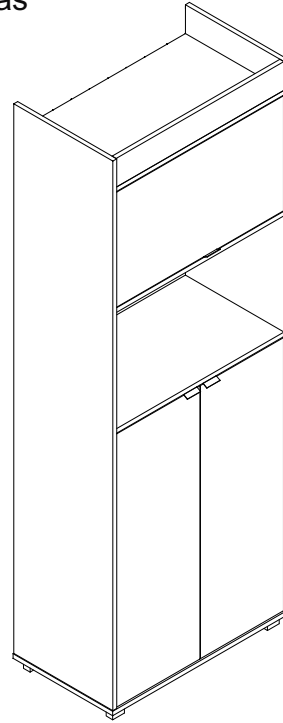

Limpeza
Cleaning
Limpieza

Pano levemente umedecido com água, seguido de pano seco, não utilizar produtos químicos ou abrasivos.
You can clean the product with slightly dampened cloth followed by a dry cloth. Do not use chemicals or abrasives.
Solamente utilizar un paño húmedo y después un paño seco, no utilice productos químicos o abrasivos.

Todas as peças do móvel foram marcadas com um número. Antes de começar a montagem, identifique as peças numeradas em relação às instruções de montagem. Uma vez concluída a montagem, os números podem ser facilmente removidos com um pano ligeiramente embebido em álcool. Use álcool apenas para remover números das peças.

All the furniture parts have been marked with a number. Before you start assembling, please identify the numbered parts in relation to the assembly instructions. Once assembly is completed, the numbers can be easily removed with a cloth slightly dampened in alcohol. Use alcohol only to remove part numbers.

Todos las piezas del mueble fueron marcadas con un número. Antes de empezar el montaje, identifique las piezas numeradas en relación con las instrucciones de montaje. Una vez que se completa el armado, los números se pueden quitar fácilmente con un paño ligeramente empapado en alcohol. Use alcohol solo para eliminar números de las piezas.

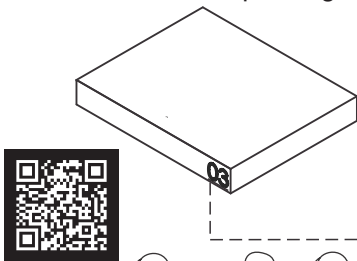

UTILIZE ALCOOL APENAS PARA REMOVER O NUMERO DAS PEÇAS
USE ALCOHOL ONLY TO REMOVE PART NUMBERS
UTILICE ALCOHOL SOLAMENTE PARA ELIMINAR EL NUMERO DE LAS PIEZAS

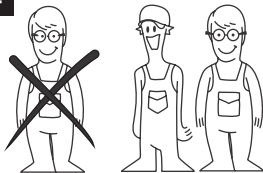

Para facilitar a montagem, utilize uma parafusadeira elétrica.
To speed assembly, use an electronic screwdriver.
Para facilitar el armado, utilice un destornillador eléctrico.

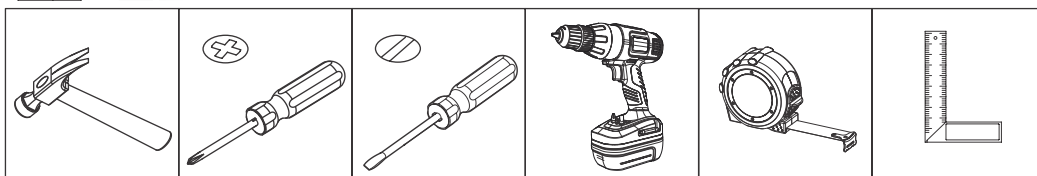

COD BR: BAM 09

PEÇA	DESCRIÇÃO	QUANT.	PART	DESCRIPTION	QTY	PIEZA	DESCRIPCIÓN	CANTIDAD
001	BASE	1	001	BASE	1	001	BASE	1
002	TAMPO	1	002	TOP	1	002	TAPA	1
003	LATERAL ESQUERDA	1	003	LEFT SIDE	1	003	LATERAL IZQUIERDA	1
004	LATERAL DIREITA	1	004	RIGHT SIDE	1	004	LATERAL DERECHA	1
005	PRATELEIRA MAIOR	2	005	LONGER SHELF	2	005	REPISA MAIOR	2
006	PRATELEIRA MENOR	1	006	LOWER SHELF	1	006	REPISA MENOR	1
007	PORTA ESQUERDA	1	007	LEFT DOOR	1	007	PUERTA IZQUIERDA	1
008	PORTA DIREITA	1	008	RIGHT DOOR	1	008	PUERTA DERECHA	1
009	PORTA SUPERIOR	1	009	UPPER DOOR	1	009	PUERTA SUPERIOR	1
010	VISTA	1	010	DETAIL	1	010	DETALLE	1
011	COSTA MAIOR	2	011	LONGER BACK	2	011	REVÉS MAIOR	2
012	COSTA MENOR	2	012	LOWER BACK	2	012	REVÉS MENOR	2
013	PÉS	4	013	FEET	4	013	PIES	4

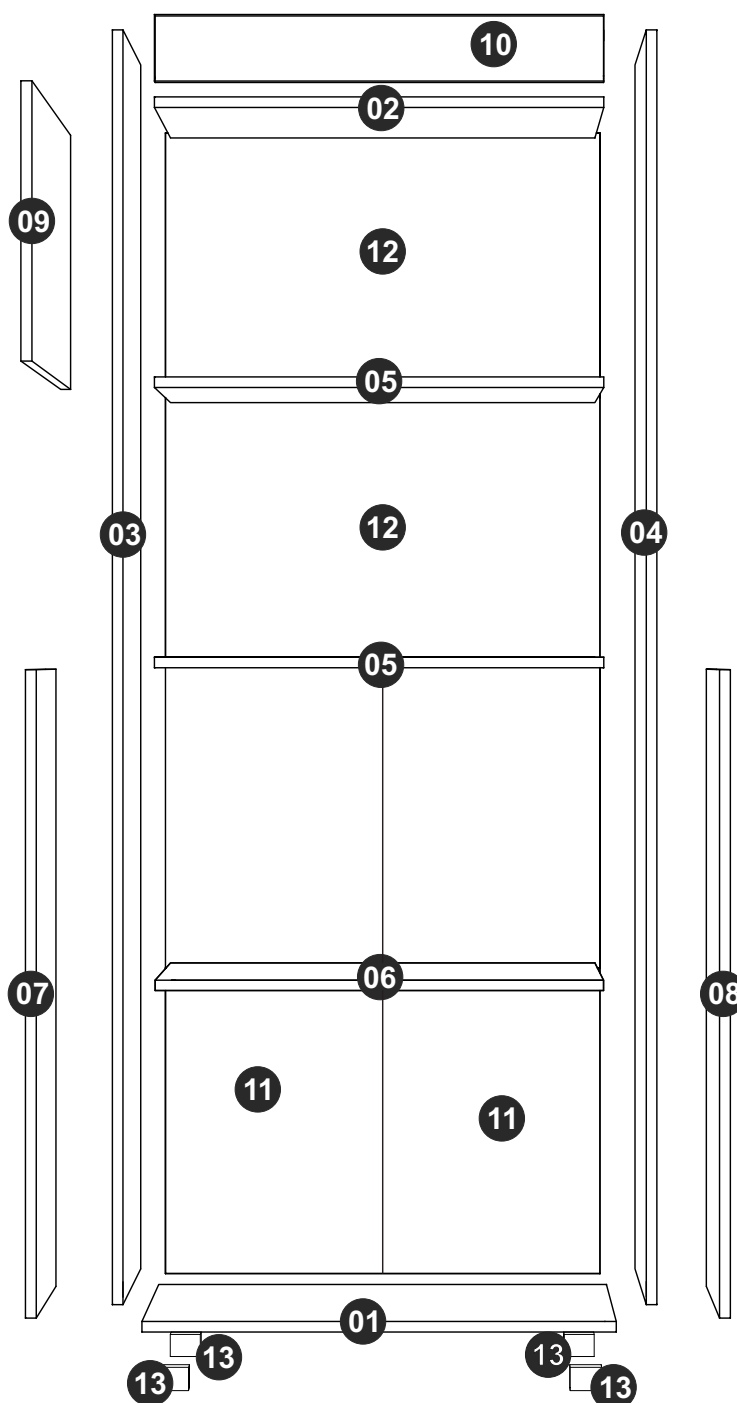

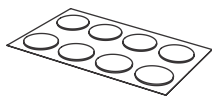

TAPA FUROS x 20
STICKER x 20
TAPAS PLÁSTICAS x 20

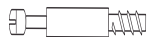

EF 000094 X 16



EF 000033x 20
8x30



EF 000216 X 16



PÉS RETÂNGULARES x 4
RETANGULAR FEET x 4
PIES RECTANGULARES x 4



EF 000381 x 08
3X25 CC

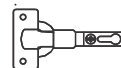

EF 000043 X 06



EF 000025 X 06



SUPORTE ANGULAR X 02
ANGULAR SUPPORT X 02
SOPORTE ANGULAR X 02



EF 000106 X 34
3,5X14 CC



EF 000107 x 02
3,5X16 CC

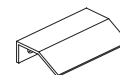

PUXADOR x 03
HANDLE x 03
MANIJA x 03



SUPORTE PLÁSTICO x 02
PLASTIC SUPPORT x 02
SOPORTE PLASTICO x 02

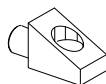

EF 000714 X 02

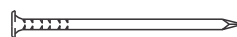

EF 000168 X 112
10X10 C/C



GIZ x 01
CHALK x 01
TIZA x 01

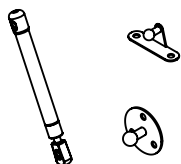

KIT AMORTECEDOR A GAS x 01
LIFT SUPPORT KIT x 01
AMORTIGUADOR A GAS x 01



EF 000132 x 04
4X50 CC



EF 000016 X 1

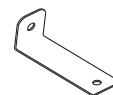

EF 000529 X 1



EF 000246 x 1
5X50 CF



EF 000248 X 1
3,5X14 CP



PERFIL H x 01
PROFILE H x 01
PERFIL H x 01

Utilize para medir as ferragens.

Utilice para medir el herraje.

Use for measuring the hardware.

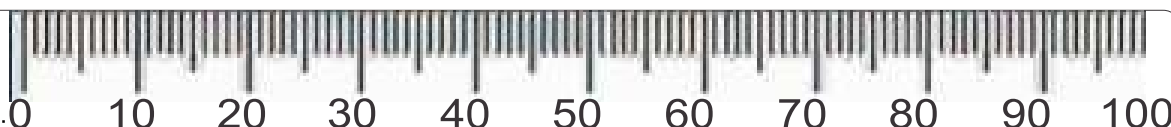

Garantia (exclusivo para o Brasil/exclusivo de Brasil/exclusive to Brazil):

A garantia dos produtos fabricados pela BRV Móveis, abrange eventuais defeitos-vícios de fabricação, no prazo estabelecido pelo código de Defesa do Consumidor, em seu artigo 26.II. o qual prevê a garantia de 90 (noventa) dias.

A = 9KG - 19.84 LB

B = 8KG - 17.63 LB

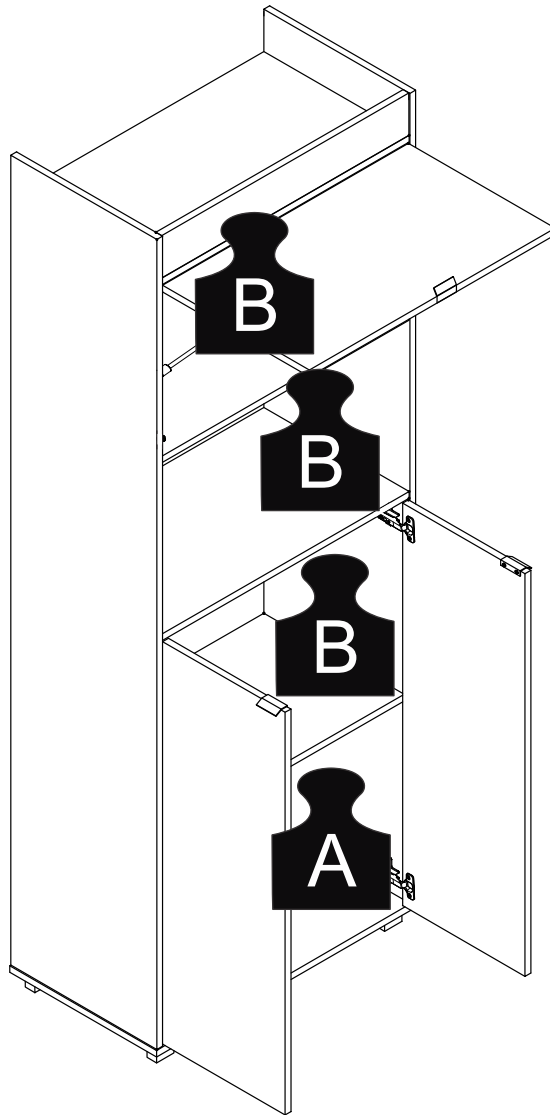

PASSO 1 / STEP 1 / PASO 1

Insira a ferragem EF 000094 nas peças 03 e 04.
Insira a ferragem EF 000714 nas peças 03 e 04.
Insira o suporte plástico nas peças 03 e 04.
Insert hardware EF 000094 into pieces 03 and 04.
Insert hardware EF 000714 into pieces 03 and 04.
Insert the plastic support into pieces 03 and 04.
Añade el herraje EF 000094 en las piezas 03 y 04.
Añade el herraje EF 000714 en las piezas 03 y 04.
Añade el soporte plástico en las piezas 03 y 04.

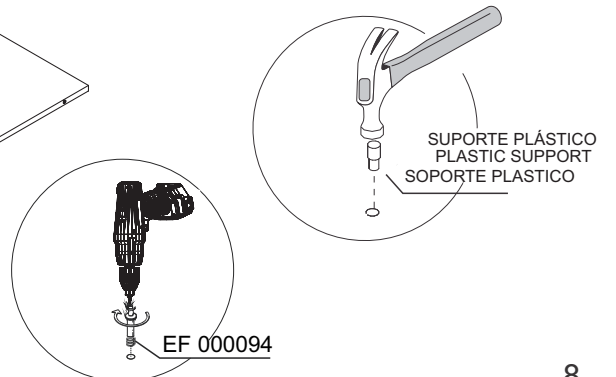
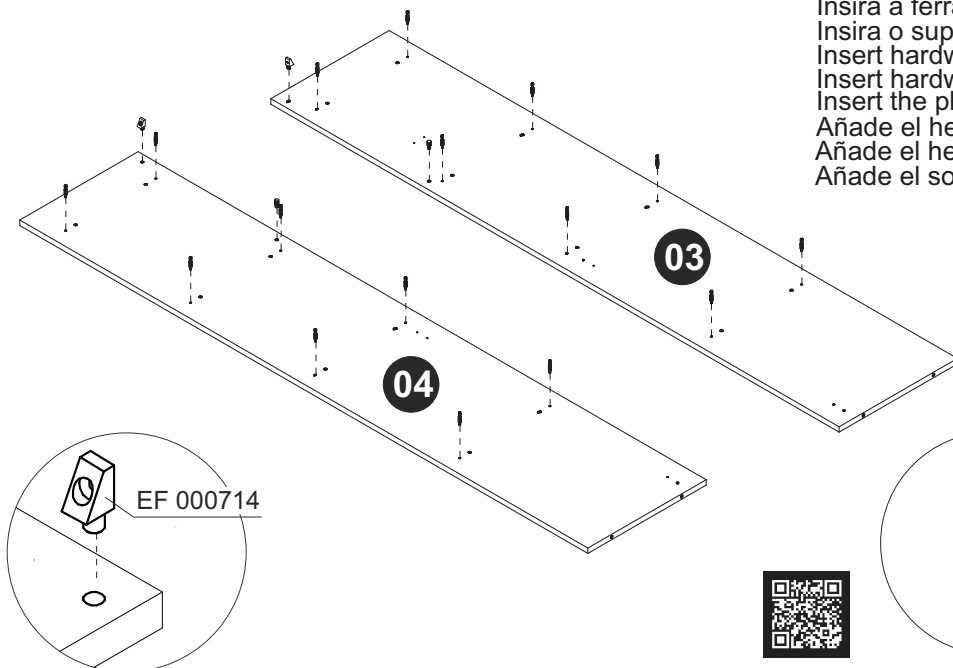

PASSO 2 / STEP 2 / PASO 2

Insira a ferragem EF 000033 nas peças 02, 03, 04, 05 e 06.
Insert hardware EF 000033 into pieces 02, 03, 04, 05 and 06.
Añade el herraje EF 000033 en las piezas 02, 03, 04, 05 y 06.

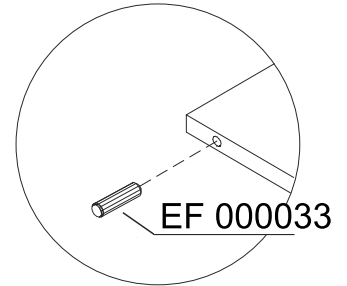
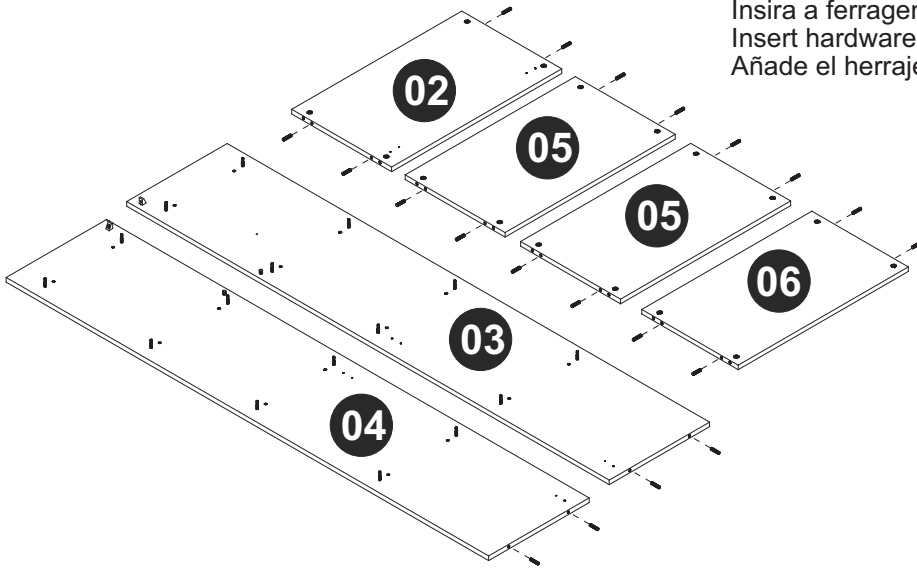

PASSO 3 / STEP 3 / PASO 3

Fixe a ferragem EF 000025 nas peças 02, 03 e 04 utilizando a ferragem EF 000106.
Attach hardware EF 000025 into pieces 02, 03 and 04 using hardware EF 000106.
Fije el herraje EF 000025 en las piezas 02, 03 y 04 utilizando el herraje EF 000106.

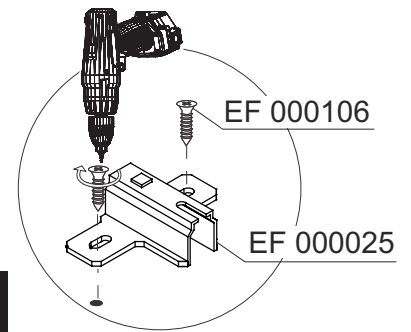
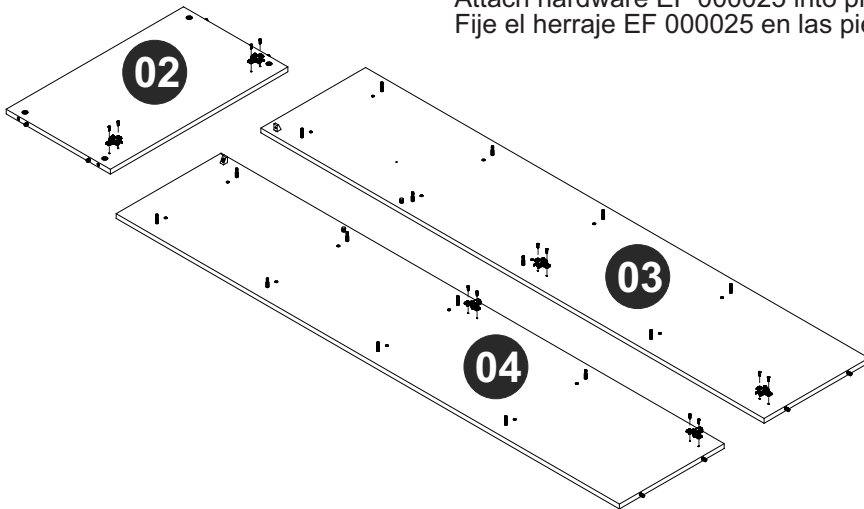

PASSO 4 / STEP 4 / PASO 4

Fixe o suporte angular na peça 10 utilizando a ferragem EF 000106.
Attach the angular support into piece 10 using hardware EF 000106.
Fije el soporte angular en la pieza 10 utilizando el herraje EF 000106.

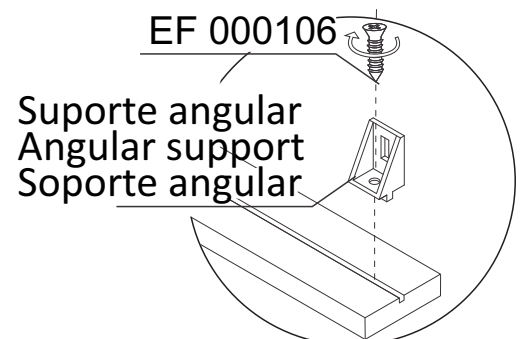
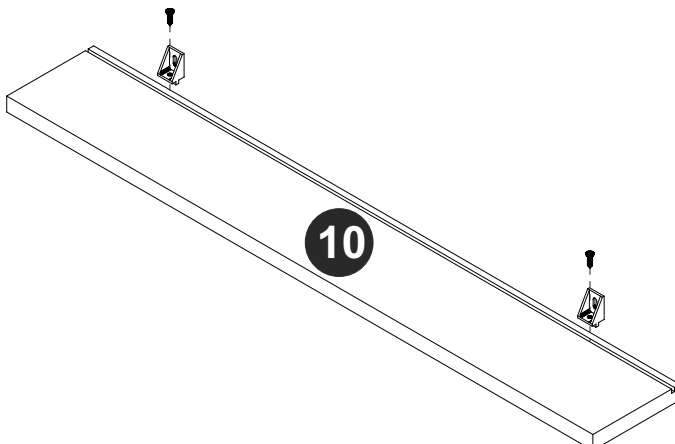

PASSO 5 / STEP 5 / PASO 5

Fixe a ferragem EF 000043 e o puxador usando a ferragem EF 000106.
Fix hardware EF 000043 and the handle using hardware EF 000106.
Fije el herraje EF 000043 y la manija utilizando el herraje EF 000106.

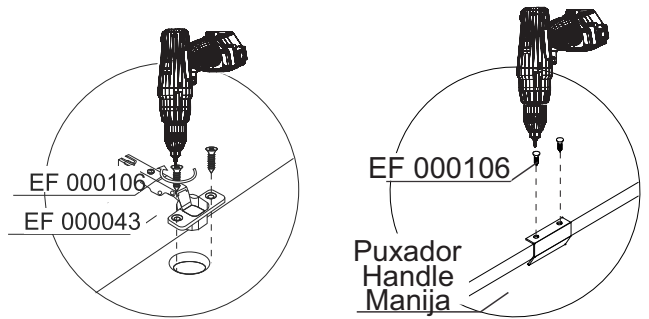
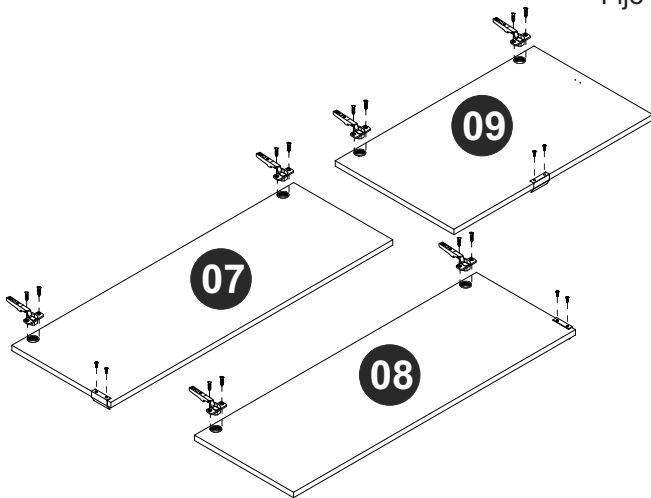

PASSO 6 / STEP 6 / PASO 6

Conecte as peças 02, 05 e 06 na peça 03, insira a ferragem EF 000216 e gire para apertar.
Connect pieces 02, 05 and 06 into piece 03, insert hardware EF 000216 and turn to tighten.
Junte las piezas 02, 05 y 06 en la pieza 03, añada el herraje EF 000216 y gire para apretar.

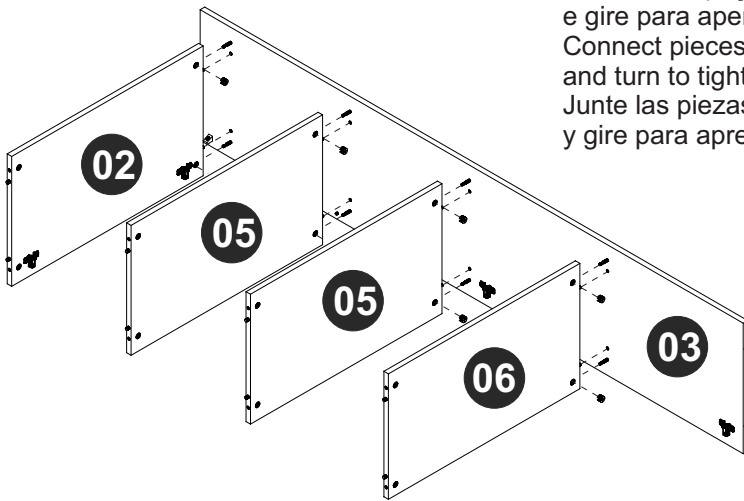

Por favor, observe a posição da ferragem EF 000025
Please, note hardware EF 000025 position.
Por favor, observe la posición del herraje EF000025.

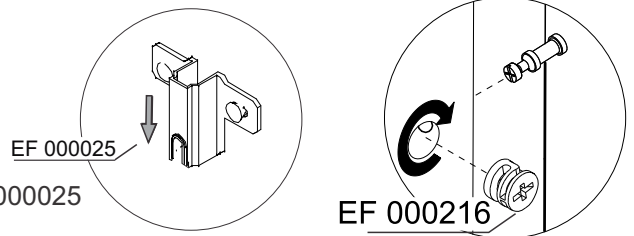

PASSO 7 / STEP 7 / PASO 7

Conecte a peça 04 à parte montada no passo anterior, insira a ferragem EF 000216 e gire para apertar.
Connect piece 04 to the part assembled into the previous step, insert hardware EF 000216 and turn to tighten.
Junte la pieza 04 a la parte armada en el paso anterior, añada el herraje EF 000216 y gire para apretar.

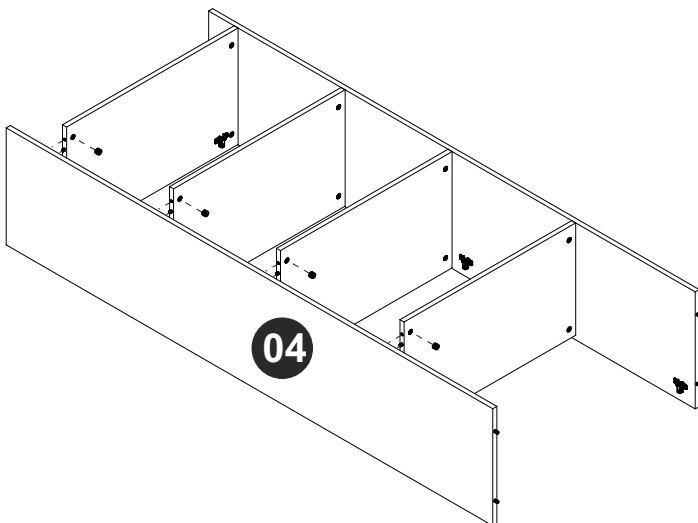

Por favor, observe a posição da ferragem EF 000025
Please, note hardware EF 000025 position.
Por favor, observe la posición del herraje EF000025.

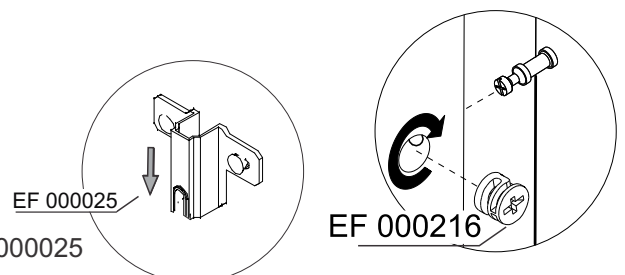

PASSO 8 / STEP 8 / PASO 8

Fixe a peça 10 utilizando a ferragem EF 000106 e EF 000107.
Fix the piece 10 using hardware EF 000106 and EF 000107.
Fije la pieza 10 utilizando el herraje EF 000106 y EF 000107.

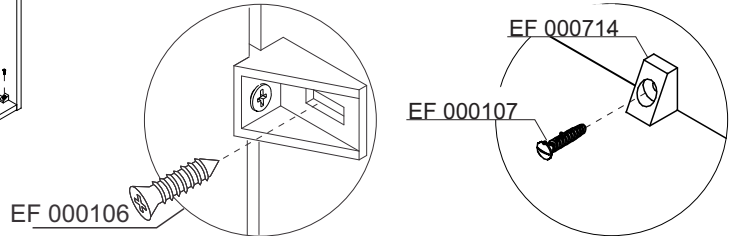
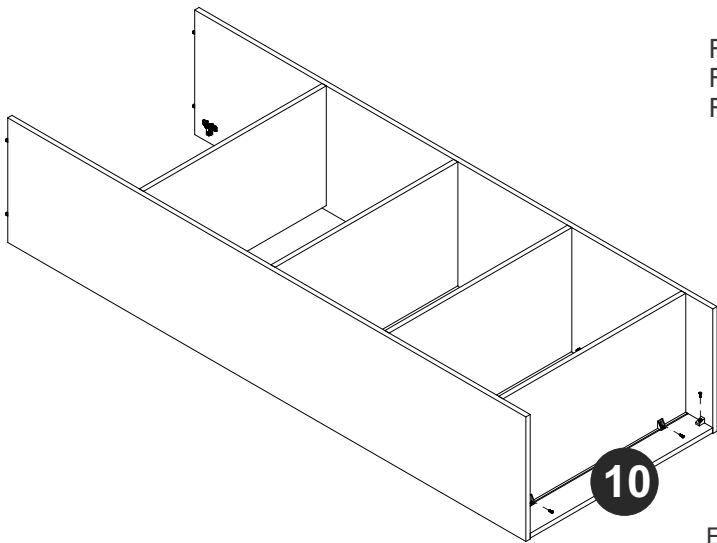

PASSO 9 / STEP 9 / PASO 9

Conecte a peça 01 ao móvel montado utilizando a ferragem EF 000132.
Connect piece 01 at the assembled furniture using hardware EF 000132.
Junte la pieza 01 al mueble armado utilizando el herraje EF 000132.

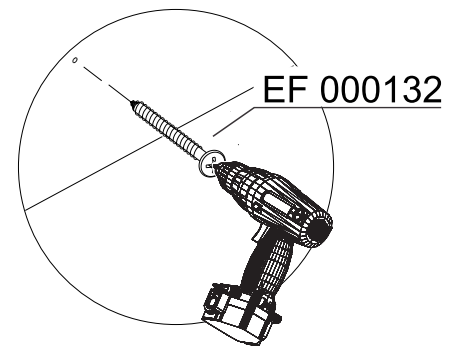
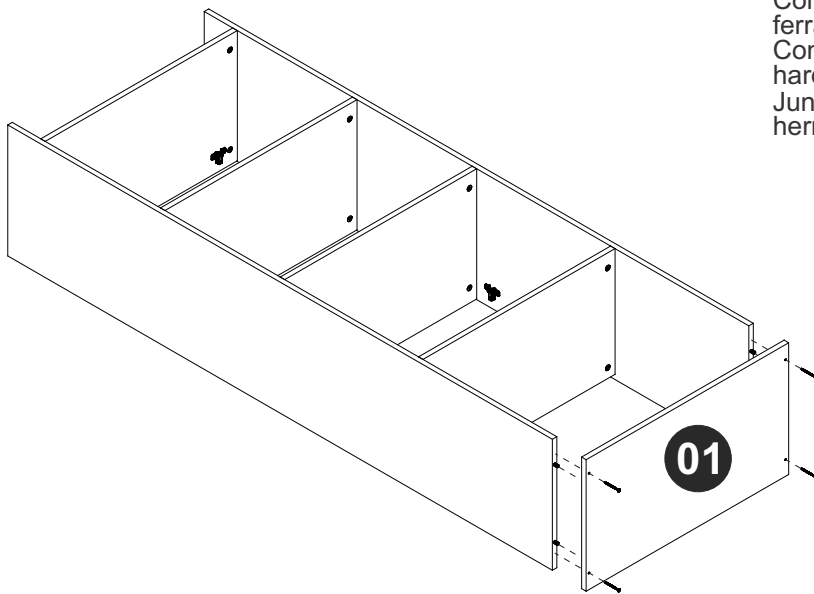

PASSO 10 / STEP 10 / PASO 10

Fixe os pés retangulares na peça 01 utilizando a ferragem EF 000381.
Fix the rectangular feet at piece 01 using hardware EF 000381.
Fije los pies rectangulares en la pieza 01 utilizando el herraje EF 000381.

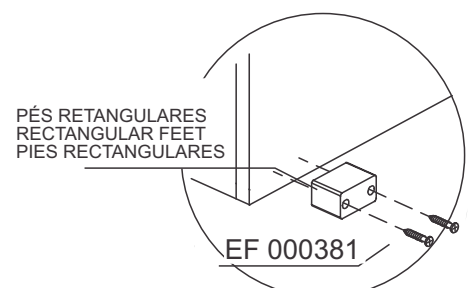
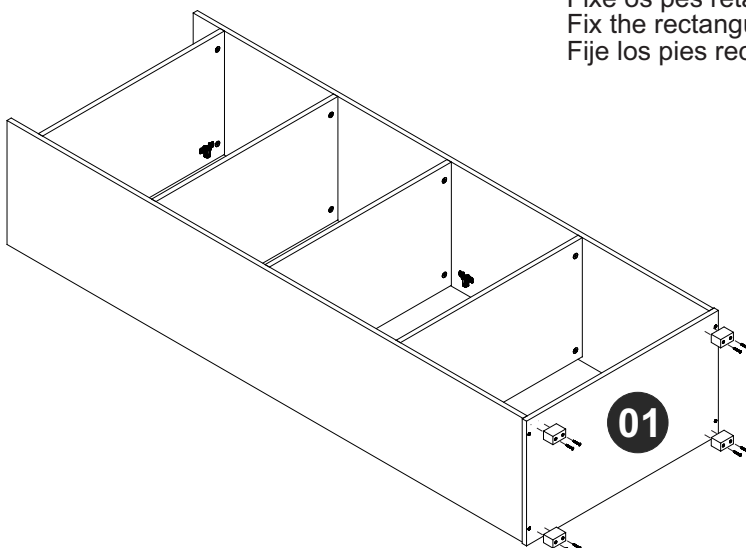

PASSO 11 / STEP 11 / PASO 11

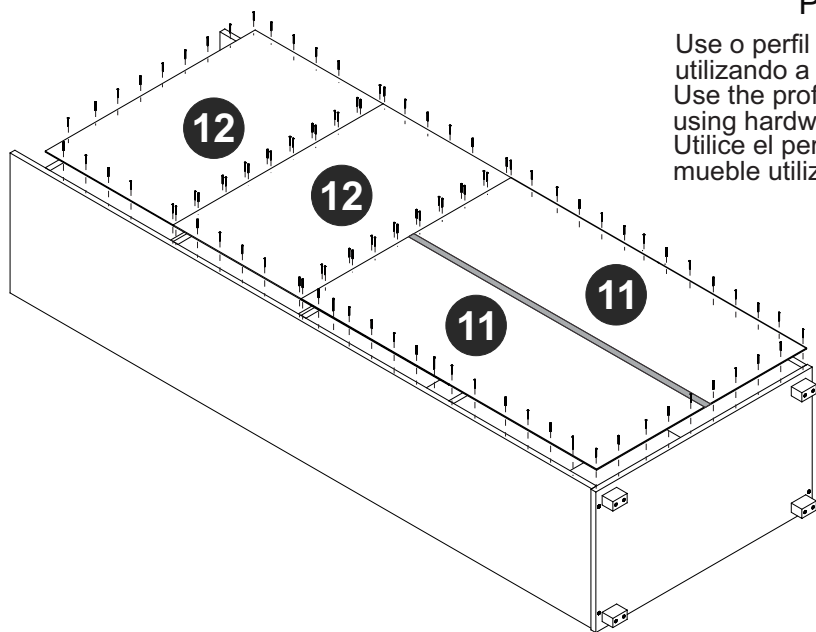

Use o perfil H para unir as peças 11, fixe as peças 11 e 12 ao móvel utilizando a ferragem EF 000168.
Use the profile H to join pieces 11, fix pieces 11 and 12 at the furniture using hardware EF 000168.
Utilice el perfil H para juntar las piezas 11, fije las piezas 11 y 12 al mueble utilizando el herraje EF 000168.

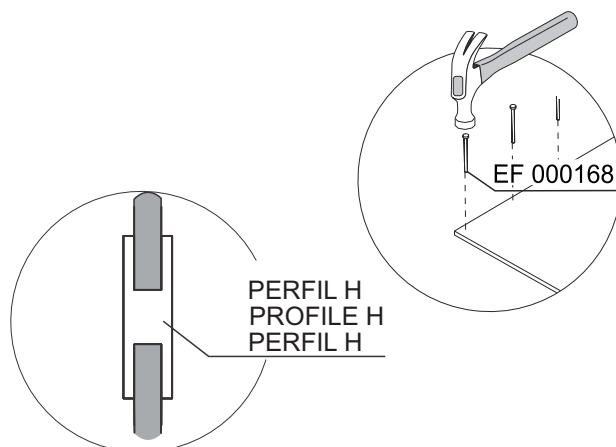

PASSO 12 / STEP 12 / PASO 12

Fixe as peças 07, 08 e 09 ao móvel montado.
Fix pieces 07, 08 and 09 to the assembled furniture.
Fije las piezas 07, 08 y 09 al mueble armado.

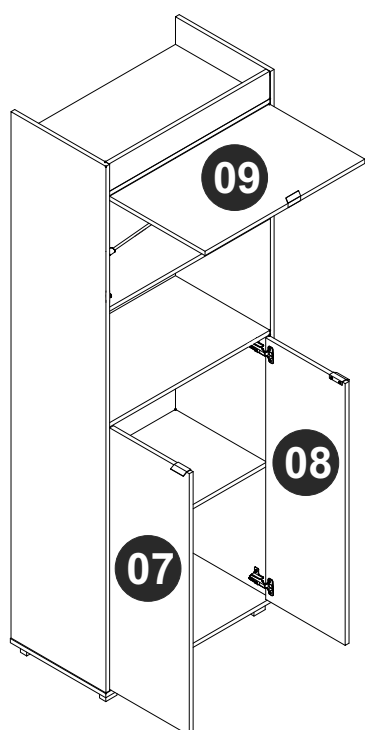

Fixe as partes 1 e 2 utilizando a ferragem EF 000106 de acordo com a imagem. Encaixe a parte 3.
Attach the parts 1 and 2 using hardware EF 000106, according the image then fit the part 3.
Fije las partes 1 y 2 utilizando el herraje EF 000106 de acuerdo con la imagen, junte la parte 3.

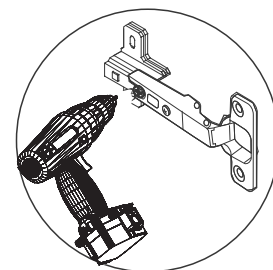
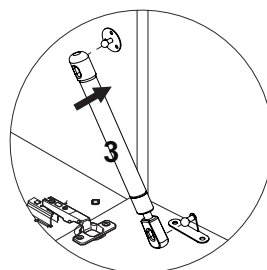
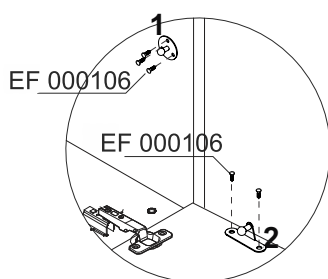

PASSO 13 / STEP 13 / PASO 13

Use o parafuso EF 000248 para fixar a ferragem EF 000529 ao móvel.
Use hardware EF 000248 to fix the hardware EF 000529 at the furniture.
Utilice el herraje EF 000248 para fijar el herraje EF000529 al mueble.

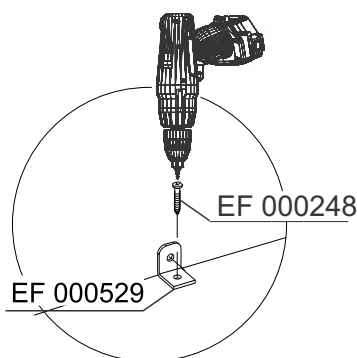
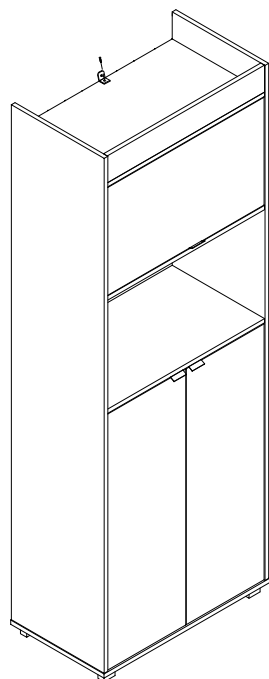

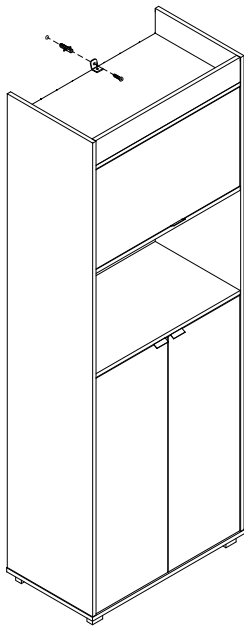

PASSO 14 / STEP 14 / PASO 14

Use as ferragens EF 000246 e EF 000016 para fixar o móvel na parede.
Use hardware EF 000246 and EF 000016 for fixing the furniture on the wall.
Utilice los herrajes EF000246 y EF000016 para fijar el mueble en la pared.

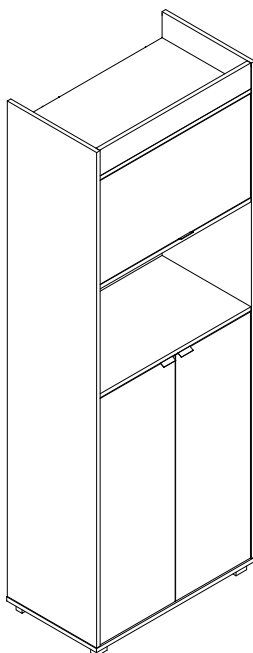
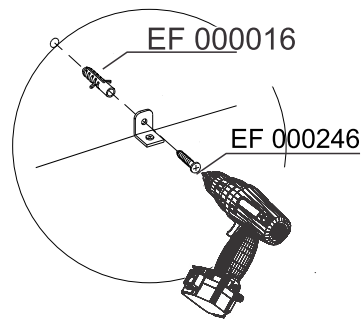

PASSO 15 / STEP 15 / PASO 15

Utilize o tapa furos para cobrir os parafusos aparentes.
Use the sticker to cover the apparent screws.
Utilice los tapa huecos para cubrir los tornillos aparentes.

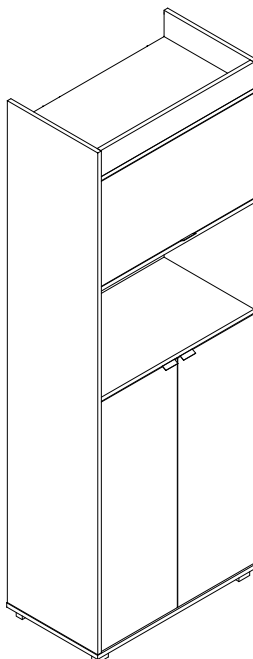
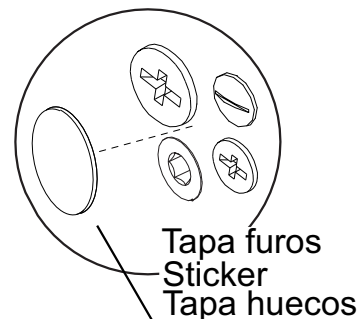

PASSO 16 / STEP 16 / PASO 16

Utilize o giz para dar o acabamento final ao produto.
Use the chalk to give the final finish on the product.
Utilize la tiza para dar el acabado final al producto.

